

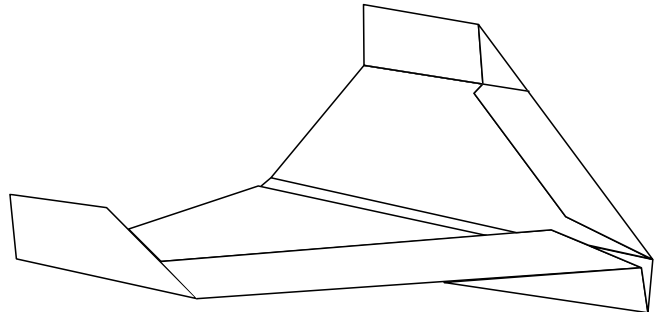

Smoother interaction with
management + shared knowledge +
automation of processes = time saved
+ increased employee collaboration.



The Client

When an airline company which is one of the largest in India, with operations across India connecting 64 destinations with a fleet of 43 aircrafts, and catering to 9 million travelers across India approached us with dilemmas they were facing, it didn't take more than imorfus to set it right for them.



Problem

For an airline company, growth at a phenomenal pace brought with it an influx in the number of employees. And soon, the company was finding it hard to run the enterprise with the regular operational practices like printing of thousands of salary slips leading to blocking of resources and logistics. Some of the problems included:

- Lack of an appropriate system to access information like corporate policies
- Lack of interaction within the enterprise, owing to multiple locations and multiple information platforms
- Delay in sharing information
- No centralized record of attendance and leave
- Generation of salary slips on print

Insight

Our understanding of the client's needs led to the creation of a common platform to address the needs and demands of all its employees that led to:

- Automated Business workflow, Administration management, and Training management.
- Building applications for Human resource, Finance, and IT infrastructure.

Solution

imorfus, an intranet solution that addresses the many needs of an enterprise, and connects it effectively was implemented. Our solution was to:

- Interface with the backend CRS system to track receivables from travel agents.
- Seamlessly integrate heterogeneous applications for displaying information relevant to user profile.
- Integrate attendance management and payroll.



Results

The results of implementing imorfus in this airline company were:

- Increased collaboration amongst employees
- Smoother interaction with the management
- Shared knowledge
- Automation of Leave applications, Salary slip uploads and Claims re-imbusement

Implementation

Best practices in the intranet assured benefits like organized work flow, right communication channel between the management and employees and, importantly, increased efficiency through automation. Some of the modules of imorfus - Intranet Solution that were used for this client include:

- CAPEX (Capital Expenditure)
- Employee travel ticket requisitions
- HR portal for managing employee records
- Software updates disbursement system for upgrades to in-flight software



Stay in control of time-to-market issues.
Manage recruitment and retention. Have an updated appraisal status. Stay in touch with Project Delivery timelines. Manage partners effectively. Help your organization reduce costs. Improve information management. Communicate financial information effortlessly for decision making.

You can now do all these and more with imorfus.

To know more, please contact:

i-Vista Digital Solutions Pvt. Ltd.

sales@ivistasolutions.com

+91 80 4196 6600